

# Scambiatori di calore serie "ST2100" aria-olio Air-oil heat exchangers series "ST2100"



## CARATTERISTICHE TECNICHE DEL GRUPPO DI VENTILAZIONE TECHNICAL FEATURES

Tipologia Type	Frequenza Frequency Hz	Tensione Voltage V	Giri/min RPM N.°	Potenza Power kW	Ø ventola Ø FAN (mm)	dB (A)	Q air (m³/h)	Cap. (lt)	Peso Weight (kg)	IP
12	DC	12	3000	0.175	305	79	2100	1.5	8.5	67
24	DC	24	3000	0.175	305	82	2200	1.5	8.5	67

Portata olio consigliata da 15 a 70 (lt/min)  
Suggested oil flow from 15 to 70 (lt/min)

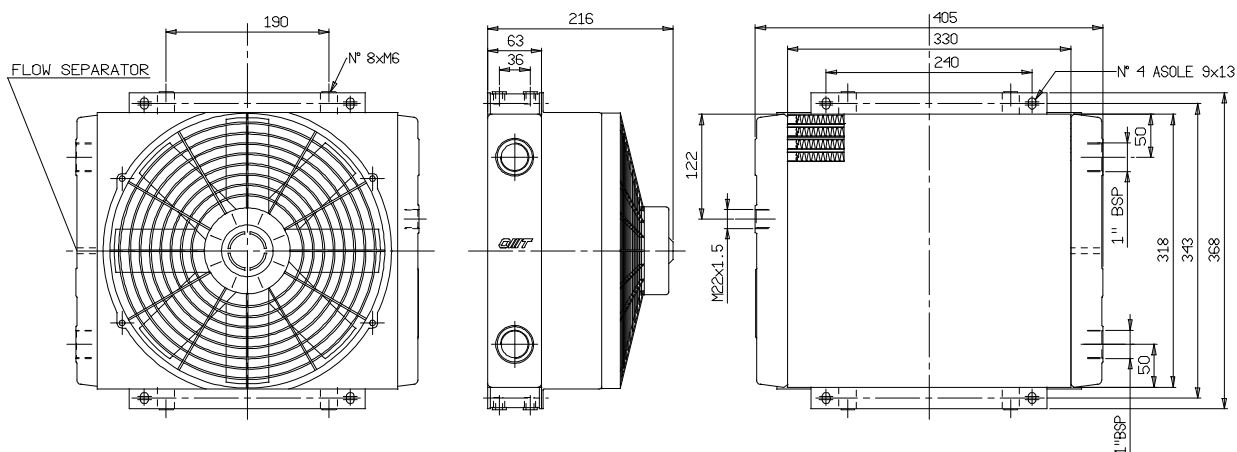

## COEFFICIENTE DI CORREZIONE CORRECTION FACTOR

CST	10	15	20	32	40	50	60	80	100	200
F	0.51	0.66	0.76	1	1.22	1.4	1.6	1.9	2.1	3.4

## DIAGRAMMA DI RENDIMENTO PERFORMANCE DIAGRAM

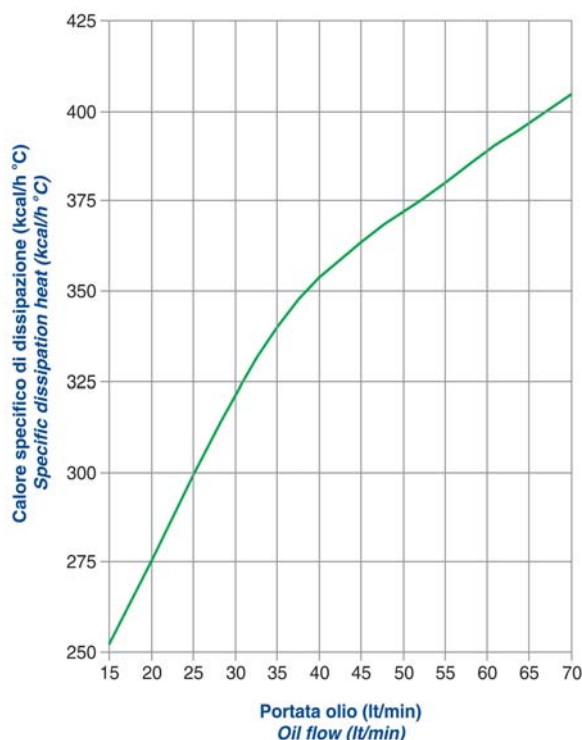

## DIAGRAMMA PERDITE DI CARICO (32 cst) PRESSURE DROP DIAGRAM (32 cst)

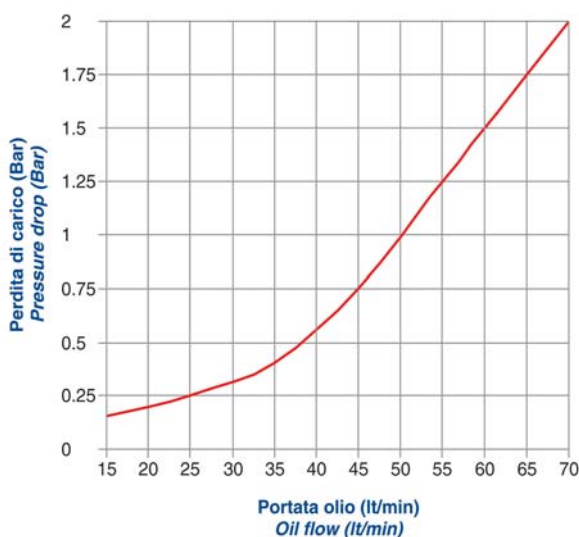

Le dimensioni di ingombro e le caratteristiche tecniche non sono impegnative  
Over-all dimensions and technical characteristic are not binding