

Scambiatore tipo SS10 Serie Aria-Olio Heat exchanger series SS10 Air-Oil version



CARATTERISTICHE TECNICHE DEL GRUPPO DI VENTILAZIONE TECHNICAL FEATURES

Tipologia Type	Frequenza Frequency Hz	Tensione Voltage V	N° Giri/min RPM	Potenza Power kW	Diam. Ventola Ø FAN (mm)	dB (A)	L (mm)	Q air (m³/h)	Cap. (lt)	Peso Weight (kg)	IP
01	50/60	230	2650/3000	0.050/0.046	170	63	125	500	0.28	6	44
03	50/60	400	2750/3100	0.045/0.043	170	63	125	500	0.28	6	44
12	DC	12	4000	0.080	167	64	158	550	0.28	5	65
24	DC	24	4100	0.080	167	64	158	550	0.28	5	65

Portata olio consigliata da 5 a 40 (lt/min)
Suggested oil flow from 5 to 40 (lt/min)

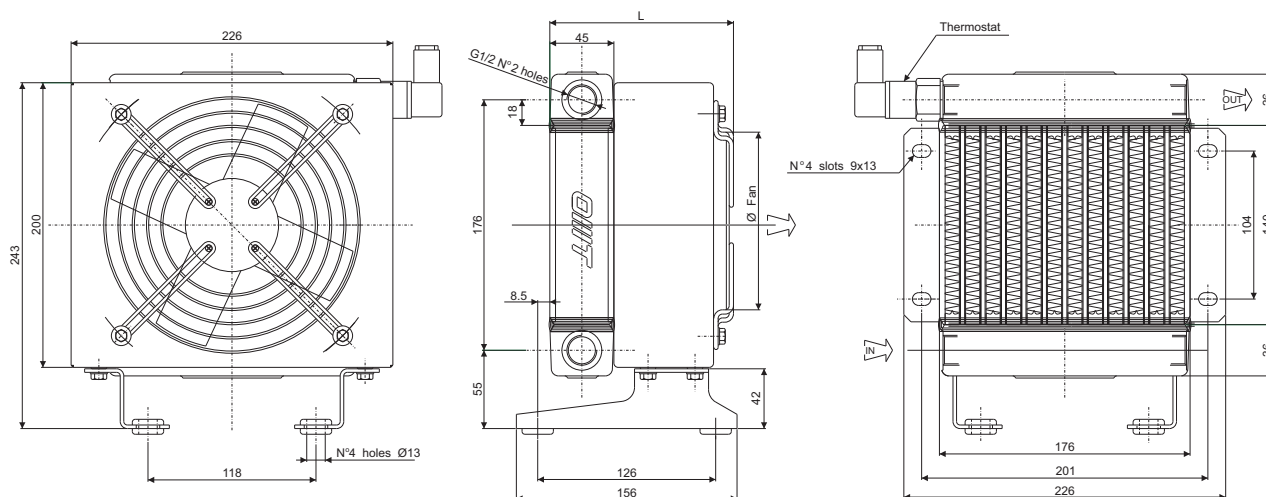

Coefficiente di correzione Correction factor

CST	10	15	20	32	40	50	60	80	100	200
F	0.51	0.66	0.76	1	1.22	1.4	1.6	1.9	2.1	3.4

Diagramma di rendimento Performance diagram

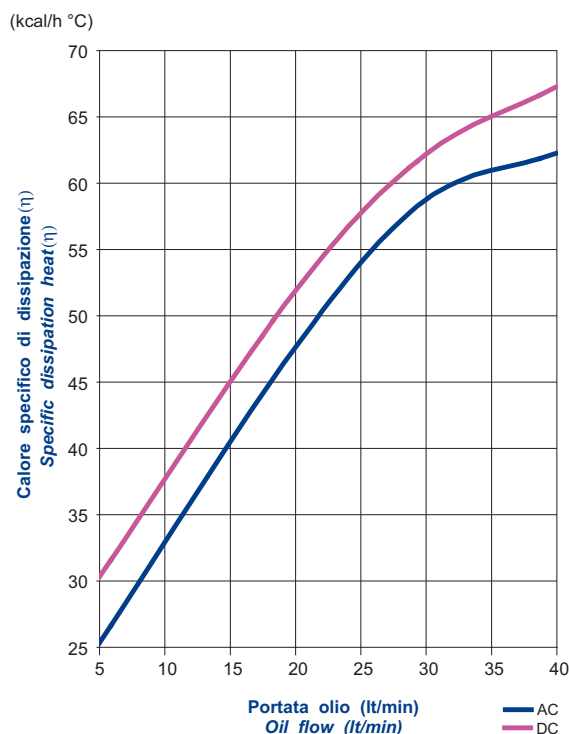

Diagramma perdite di carico (32 cst) Pressure drop diagram (32 cst)

