

Integral electronic drivers type E-RI-AEG

digital, with cycle generator - for proportional directional valves without transducer

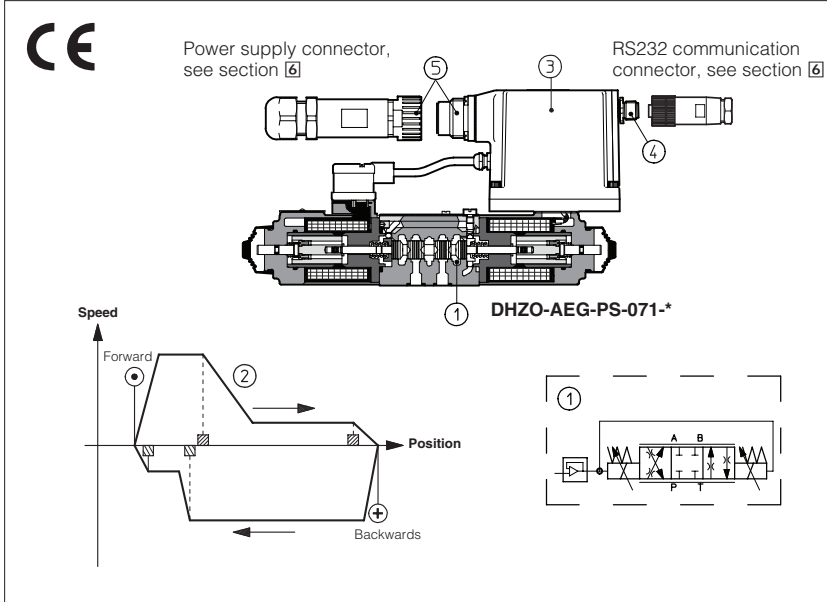

These digital drivers are integral to Atos proportional directional valves without transducer and they control the current to the solenoid, regulating the spool position (1) proportionally to a digital programmed reference signal.

Two modes of operation are available:

- Mode A: the driver automatically handles forward/backward working cycles with fast-slow speed control. The digital driver receives ON/OFF inputs from the local proximity microswitches (f1...f4) and command signals (start forward/backward) from the machine control unit and thus activates the corresponding cycle phase.
- Mode B: the driver actuates up to six different phases (speed + ramp), according to the configuration of the ON-OFF command signals on the supply connector. An external PLC may control the desired working cycle by generating the command signals to the digital driver.

Features:

- software setting of cycle configuration (2)
- integral digital electronics (3), factory pre-set
- configuration of the cycle's parameters (speed, ramps) via RS232 serial communication interface
- software setting of the main functional parameters as bias, scale, ramps, by means of the relevant programming device Kit-E-SW-PS, see section 9
- possibility to optimize the application performance modifying via software the internal parameters as the regulation characteristic of the valve (linearization)
- 12 pins power supply connector (5) arranged to receive the power supply and the ON-OFF input command signals for the cycle generator
- 5 pins standard M12 connector (4) dedicated to the serial RS232 connection with PC
- IP67 protection degree
- 3,3A maximum current to the coils
- CE marking granting the conformity to the EMC Directive (Electromagnetic Compatibility)

1 MODEL CODE: PROPORTIONAL VALVES WITH INTEGRAL DIGITAL DRIVERS TYPE E-RI-AEG

E-RI	-	A	-	EG	-	PS	-	01H	*	**	/	*
Integral electronic driver												
A = without transducer												
EG = with integral digital electronic and cycle generator												
PS = serial RS232 communication												
01H = for single solenoid proportional valves 05H = for double solenoid proportional valves												
Set code (see note)												
Series number												

Note: the set code identifies the correspondance between the digital integral driver and the relevant valve.

2 ELECTRONIC AND WIRING BLOCK DIAGRAM

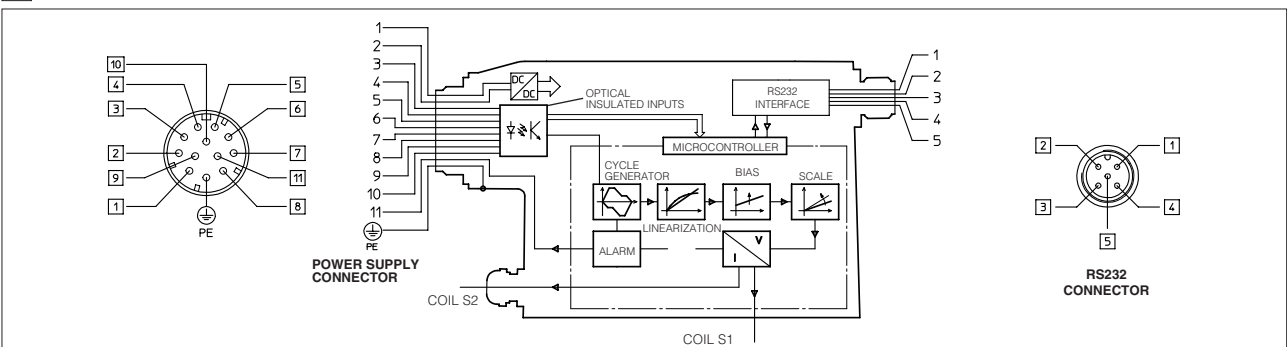

SUPPLY CONNECTOR			COMMUNICATION CONNECTOR		
PIN	SIGNAL DESCRIPTION	TECHNICAL SPECIFICATION	Communication options	-PS (RS232)	
1	Power supply 24 V _{DC}	Stabilized: +24V _{DC}	Pin number Signal description	NC	
2	Power supply zero	Filtered and rectified: V _{rms} = 21 ÷ 33 (ripple max 2 V _{pp}) Not active: 0 V _{DC} , connected to pin 2		1	Not connected
3	Enable	Active: 24 V _{DC} , optical insulated input (threshold 9,7V) Floating: manual forward/backward movements possible		2	NC Not connected
4	F1	COMMAND SIGNALS Optical insulated input 0 ÷ 24 V _{DC} (threshold 9,7 V) - referred to pin 10		3	RS_GND Signal zero data line
5	F2			4	RS_RX Valve receiving data line
6	F3		5	RS_TX Valve transmitting data line	
7	F4				
8	F5 (Start Forward for Mode A)				
9	F6 (Start Backward for Mode A)				
10	ON/OFF GND	optical insulated input GND (ø V for F1÷F6)			
11	Fault	Output 0 ÷ 24 V _{DC} (max 30 mA)			
PE	Earth	Connect only when the power supply don't conform to VDE 0551 (CEI 14/6)			

Note: female plug connectors can be supplied separately on request

3 MAIN CHARACTERISTICS OF E-RI-AEG ELECTRONIC DRIVERS

Driver section	
Format	Sealed box on the valve - Protection: IP67 DIN 40050 - Insulation: VDE0110
Electromagnetic compatibility (EMC)	Emission: EN 50081-2 - Immunity: EN 50082-2
Max power consumption	50 W
Current supplied to solenoids	$I_{max} = 3.3$ A square wave PWM type
Operating temperature	$-20^{\circ}\text{C} \div +60^{\circ}\text{C}$ (storage $-20^{\circ}\text{C} \div +70^{\circ}\text{C}$)
Features	Rapid solenoid excitation and switching off – Output to solenoids protected against accidental short circuits – Current control by PI actions
Alarm messages	Electronic overcurrent, overtemperature, undertemperature, output stage fault
RS232 interface section (-PS option)	
Serial input format	RS232C serial connection
Communication Protocol	Atos Protocol with ASCII coding
Programming Interface	Personal Computer with interface software for Windows® (KIT-E-SW-PS see tab. G500)
Notes	KIT-E-SW-PS, supplied separately

4 AVAILABLE SETTINGS

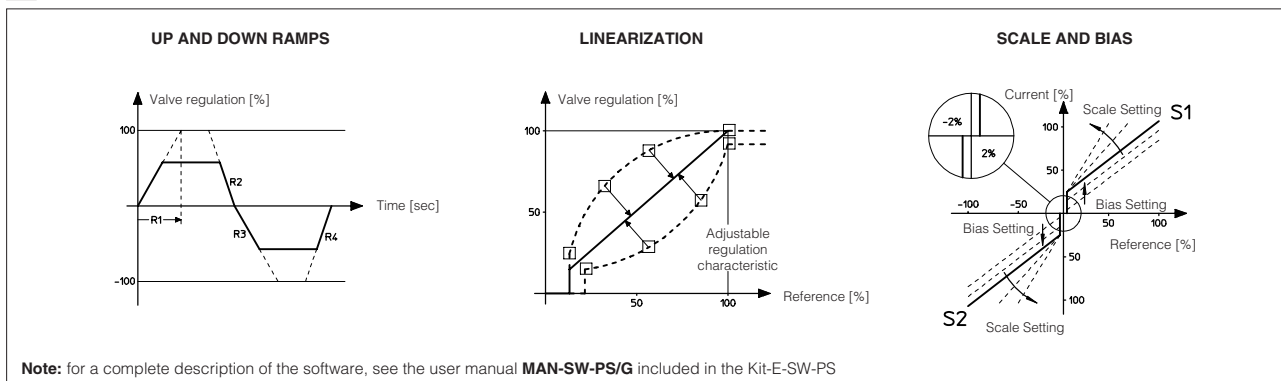

Note: dither frequency is available from 160 Hz to 500 Hz (home setting 200 Hz) - Consult our technical office

5 DIMENSIONS OF THE ELECTRONIC DRIVER AND CONNECTORS [mm]

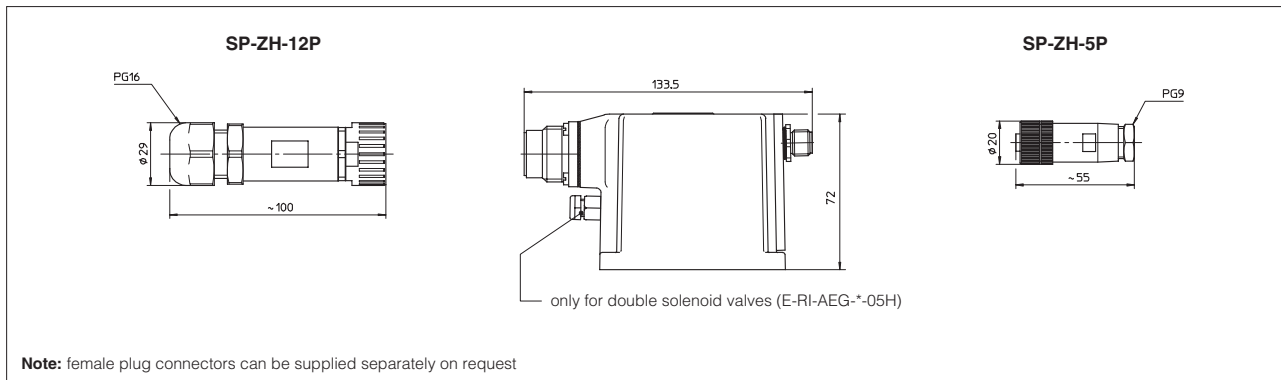

6 MODE A

When Mode A is active, the driver automatically handles forward/backward working-cycles with fast-slow speed control according to the programmed cycle. The digital driver reads the signals from the local proximity micro-switches (f1...f4) and from the ON/OFF command signals (start forward/backward) and consequently activates the various phases (speed + ramp).

The local proximity microswitches and the command signals are connected to the supply connector (F1...F6, Fig. 1).

The working cycle is thus self generated and actuated by the above signals, in particular:

- start forward signal (connected to F5) activates the forward movement;
- microswitch signals (f1.... connected to F1....) sequence the forward cycle phases;
- start backward signal (connected to F6) activates the backward movement.
- microswitch signals (...f4 connected to ...F4) sequence the backward cycle phases;

Features:

- maximum total four phases selectable (forward plus backward); maximum three phases selectable for each direction;
- for each of the four phases the following parameters can be set (Fig. 2):
 - speed regulation V_n : corresponding to the driving current and therefore to the valve opening;
 - ramp time R_n : time for a 0÷100% speed step ($V_n - V_{n-1}$).
- automatic / on input start: for each direction (forward or backward) it is possible to choose if the start movement of that direction is activated automatically at the end of the previous phase or on input (F5 for Start Forward, F6 for Start Backward);
- polarity: each proximity switch can be set as normally closed / normally open;
- type: each proximity switch signal can be set as impulsive / continuous;
- diagnostic:
 - actual phase, showing the active phase during the cycle;
 - actual direction, showing the active direction during the cycle.
- input state, showing F1 ÷ F6 electrical state (ON/OFF)
- configurable direction with positive reference signal ($P \rightarrow A$ or $P \rightarrow B$ of the valve)

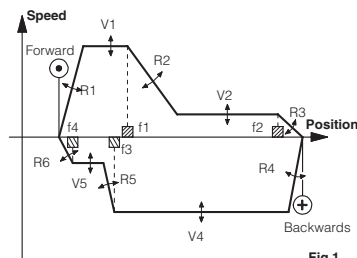
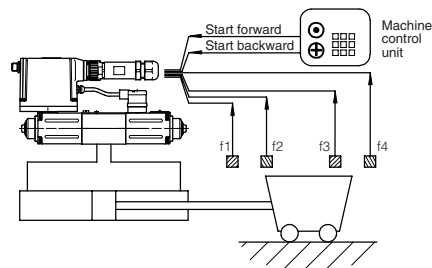

Fig.1

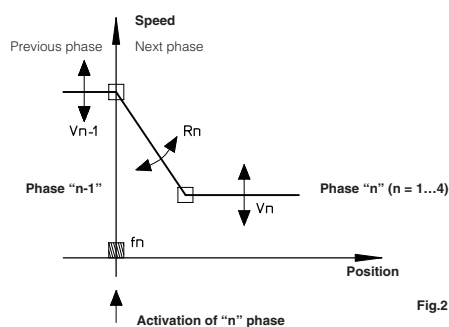

Fig.2

7 MODE B

When Mode B is active, the driver actuates up to six different phases (speed + ramp), according to the configuration of the ON-OFF command signals on the supply connector.

An external PLC may control the desired working cycle by generating the command signals to the digital driver. Therefore, this Mode of operation is the same available with the Eurocard analog driver type E-ME-AC-05F/4R-4, but with the important advantage that digital parameters assure easy, repetitive and precise settings.

Features:

- maximum six reference signals selectable;
- for each of the six signals the following parameters can be set (Fig. 2):
 - speed regulation V_n : corresponding to the driving current and therefore to the valve opening;
 - ramp time R_n : time for a 0÷100% speed step ($V_n - V_{n-1}$)
- ramp R_{stop} : ramp time when no input are selected (actuator stop)
- polarity: each proximity switch can be set as normally closed / normally opened;
- diagnostic:
 - actual phase, showing the active phase during the cycle;
 - actual direction, showing the active direction during the cycle
- configurable direction with positive reference signal ($P \rightarrow A$ or $P \rightarrow B$ of the valve)
- the operation processing of the different phases is based on the pin priority: the phase associated to the pin with higher number is performed before the phases associated to pins with lower number.

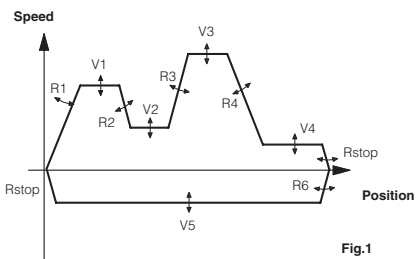
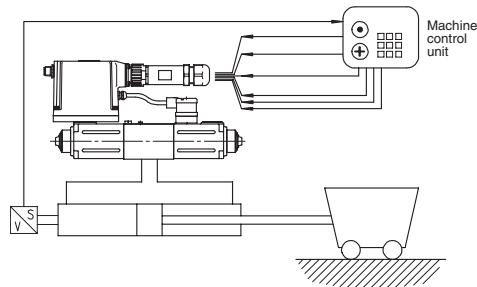

Fig.1

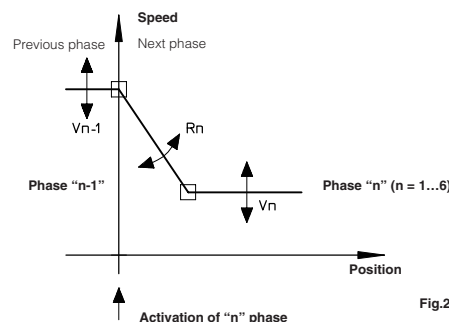

Fig.2

8 PROGRAMMING DEVICES

The functional parameters of the digital valves, as the bias, scale, ramp and linearization of the regulation characteristic, can be easily set and optimized with graphic interface by using the following software programming devices suitable for standard PC:

KIT-E-SW-PS for electronics with RS232 interface (option **-PS**)

see tab. G500 for complete information about the programming device kits and for the PC minimum requirements.

The above programming device has to be ordered separately.

9 CONNECTORS CHARACTERISTICS to be ordered separately

CONNECTOR TYPE	POWER SUPPLY CONNECTOR
CODE	SP-ZH-12P
TYPE	Female straight circular socket plug 11 pins +PE
MATERIAL	Plastic reinforced with fiber glass
CABLE GLAND	PG16
CABLE	LiYCY 10 x 0,14 mm ² (signal) LiYCY 3 x 1 mm ² (power)
CONNECTION TYPE	to crimp
STANDARD	DIN 43563
PROTECTION ACCORDING TO DIN 40050	IP 65

10 CHARACTERISTICS OF COMMUNICATION CONNECTORS (to be ordered separately)

CONNECTOR TYPE	RS232 CONNECTOR (-PS)
CODE	SP-ZH-5P
TYPE	Female straight circular socket plug 5 pins
MATERIAL	Plastic
CABLE GLAND	PG9
CABLE	CANBus Standard (301 DSP)
CONNECTION TYPE	screw terminal
STANDARD	M12 – IEC 60947-5-2
PROTECTION (DIN 40050)	IP 67